

Town of Dekorra  
 PO Box 536  
 Poynette, WI 53955  
 608-635-2014  
 townofdekorra@gmail.com

**Driveway and Access Permit Application**

Application date \_\_\_\_\_

Driveway Completion date \_\_\_\_\_

Permit # \_\_\_\_\_

Owner/Applicant Name:									
Mailing address:					City, State			Zip code	
Primary phone:			Daytime phone:			Email address:			
Request for permit at:									
Parcel number		Legal description (section, Town, range, quarter/quarter)					Road being accessed:		
Purpose of driveway:									
<b>Closest Neighbor's Address/ERNs:</b>									
	Address/ ERN	Road name	Distance to new Access/Driveway in feet	Direction to new Access/Driveway				Side of road to new Access/Driveway	
Neighbor #1				North	South	East	West	Same	Opposite
Neighbor #2				North	South	East	West	Same	Opposite

**Location**

- County Road - Access permit # \_\_\_\_\_
- Town Road
- Private Road

**Type of driveway surface**

- Concrete     Asphalt     Dirt     Sod     Gravel
- Asphalt/Concrete     Other \_\_\_\_\_

- **NO STEEL TRACKED EQUIPMENT OR VEHICLES ON TOWNSHIP ROADS – PROTECTIVE MEASURES REQUIRED WHEN LOADING, UNLOADING (UNDER TRAILER RAMPS AND TONGUE JACK, ETC) OR WHEN DRIVING HEAVY EQUIPMENT PER ORDINANCE 8.08 & 8.09.**
- **CONCRETE DRIVEWAYS SHALL TERMINATE THREE (3) FEET FROM THE EDGE OF THE CONNECTING ROADWAY. THE REMAINING THREE (3) FEET OF DRIVEWAY SHALL BE ASPHALT PAVEMENT AND MATCH TO THE CONNECTING ROADWAY.**
- County Roads require an "Access Permit" be obtained from the Columbia County Highway Department at (608)429-2156.
- Include a detailed site plan showing where the driveway/access will be located and the distances to the nearest driveways and cross streets.
- **Applicant shall place flags or markers in ditch visible from roadway at the location of proposed driveway.**

I have read and understand the terms of this permit application:

Applicant signature: \_\_\_\_\_ Date: \_\_\_\_\_

The above request has been granted on the following conditions:

- This permit is granted for a period not to exceed 12 months from issue date.
  - The applicant shall notify the Streets Department 48 hours prior to starting the work
  - **Other special provisions:** \_\_\_\_\_
- 
- **Fee is paid in full.**     FEE \_\_\_\_\_    Date Paid: \_\_\_\_\_    Check # \_\_\_\_\_

Issue date: \_\_\_\_\_ Approved and issued by: \_\_\_\_\_

# Site Plan

What is the shortest distance measured from your proposed building project to:

(These distances should also be on your site plan below)

Center line of road -----> \_\_\_\_\_ ft.

Front property line or Road Right-of-Way-----> \_\_\_\_\_ ft.

Back lot line-----> \_\_\_\_\_ ft.

Side lot line -----> \_\_\_\_\_ ft.

Side lot line -----> \_\_\_\_\_ ft.

Nearest body of water (lake, pond, river, stream)-----> \_\_\_\_\_ ft.

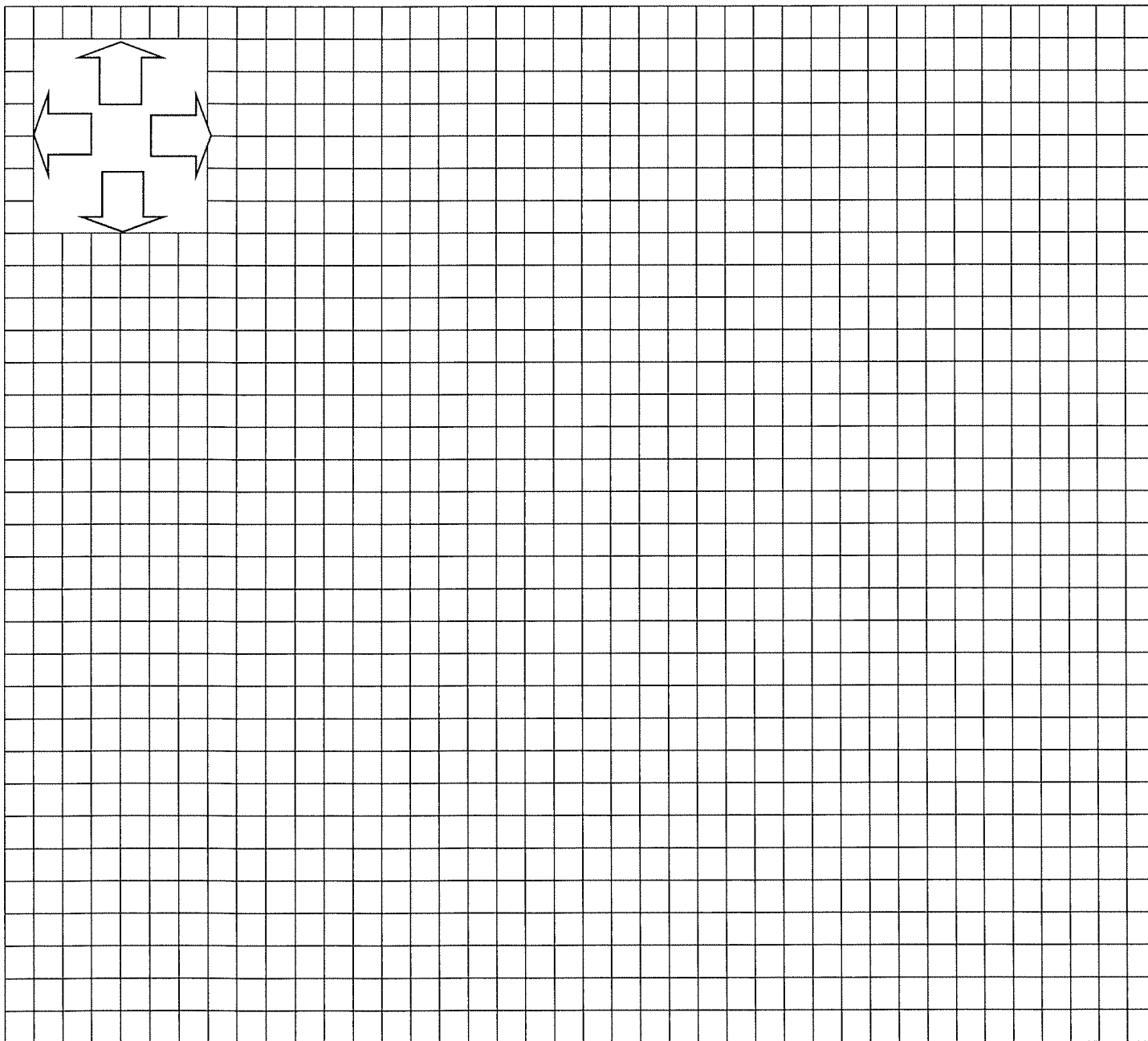

**NOTES:**

- 1. NO CONCRETE SHALL BE PLACED WITHIN 3 FEET OF EDGE OF ROADWAY.**
- 2. 2% MINIMUM DRIVEWAY CROWN OR CROSS SLOPE**

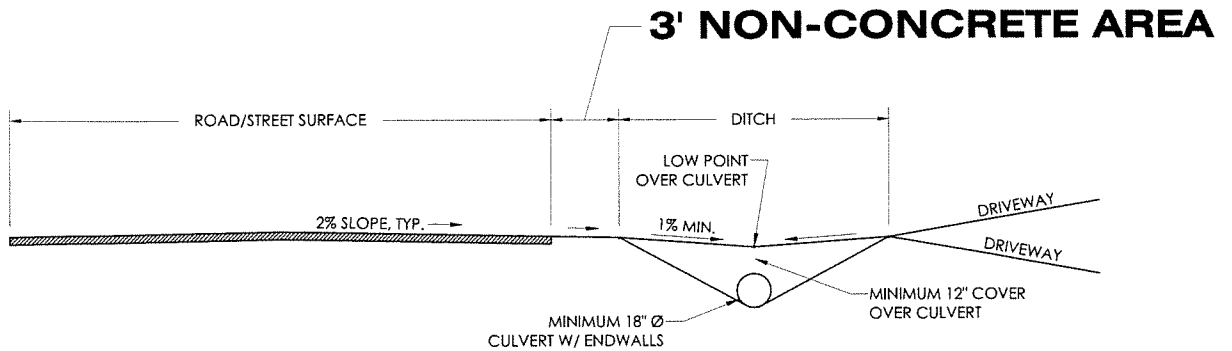

**DRIVEWAY STANDARD**

SCALE: NONE

This document contains confidential or proprietary information of General Engineering Company. Neither this document nor the information herein is to be reproduced, distributed, used or disclosed either in whole or in part except as specifically authorized by General Engineering Company.

**DRIVEWAY STANDARD**

Town of Dekorra  
Columbia County, WI

**GENERAL**  
ENGINEERING COMPANY

916 Silver Lake Dr.  
P.O. Box 340  
Portage, WI 53901  
608-742-2169  
608-742-2592 Fax  
gec@generalengineering.net

DATE Feb 2011  
BY  
GEC FILE NO. Q000-00

SHEET TITLE

**1.0**

**SECTION 8.09      MEASURES TO PROTECT TOWN ROADS.****(a)      Definitions.**

- (1)      Heavy Equipment. All vehicles not operating completely on pneumatic tires and all vehicles or combination of vehicles, other than motor buses, not licensed for operation on public highways, and having a gross weight of more than 6,000 pounds.

**(b)      Protection of Roadway.**

No person shall load, unload, drive or permit the loading, unloading or driving of heavy equipment onto the roadway of a Town highway, as defined in Wis. Stats. § 340.01(54), without placing material upon the roadway designed to protect the roadway from any damage caused by but not limited to heavy equipment, trailer tongues or ramp edges. Such protective measures for the Town roadway include, but are not limited to, mats, sand, tires or plywood sheets or a combination thereof as required to meet the particular circumstance. **[Amended by Ord. No. 2009-08, 6/23/09.]**

**(c)      Forfeiture and Penalty.**

Any person who fails to protect the Town roadway from heavy equipment by loading, unloading or driving on, as set forth in (b) above, shall be subject to forfeiture pursuant to Section 1.03 of this Code and shall be liable for the cost of repairs of damage caused. Town will have damage repaired and will bill the individual causing damage, to be paid within 30 days of billing or incur interest penalty of 1% per month.

**(d)      Exception.**

This section shall not apply to the unloading of heavy equipment onto a Town roadway when the purpose for unloading said heavy equipment is to repair or replace the section of the roadway onto which the heavy equipment is unloaded and such unloading or movement will not increase the cost of repair or replacement.

History Note: The above and foregoing Ordinance was duly adopted at a regular meeting of the Town Board of the Town of Dekorra on the 8th day of May, 2001 Ordinance 2001-05-08(b); repealed and recreated by the Town Board of Dekorra on the 9th day of September, 2003; repealed and recreated by Ord. 2007-13; amended June 23, 2009, Ord. No. 2009-08.